

# LC 205HV - 9603042

# DATA SHEET

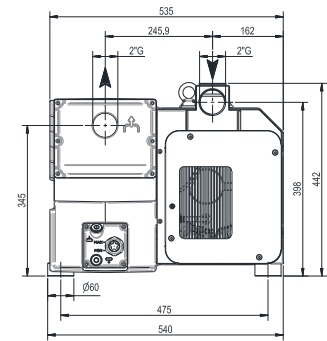
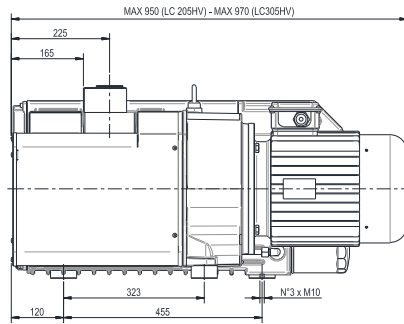

Main Accessories	LC 205HV
Minor Spare Part Kit	K9603038
Major Spare Part Kit	K9603038/1
Shock Mounts	Fitted
Inlet Filter	9001019
Inlet Filter Element	1801014
Outlet Filter	9001019
Outlet Filter Element	1801014

### PRODUCT DESCRIPTION:

The LC 205HV and LC 305HV pumps are equipped with:

- Suction fitting with double connection
- Oil check valve
- Exhaust mist eliminator
- Automatic floating oil recovery valve
- Gas ballast with manual cut-off valve
- Shock mounts
- Oil filter with by-pass
- Flexible transmission coupling

The new LC 205 and LC 305 lubricated vane vacuum pumps are available in a special HV version, suitable for packaging lines where the pump is located inside boxes.

The direction of the cooling air outlet flow is in fact downwards, so the hot air does not stagnate inside the housing.

In the LC 205HV and LC 305HV versions, the new suction fitting has a double connection to the operating line, both frontally and vertically.

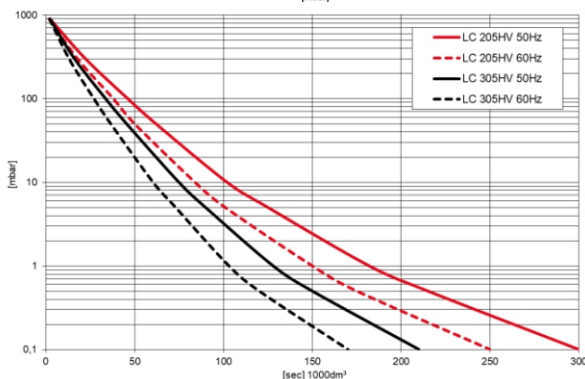
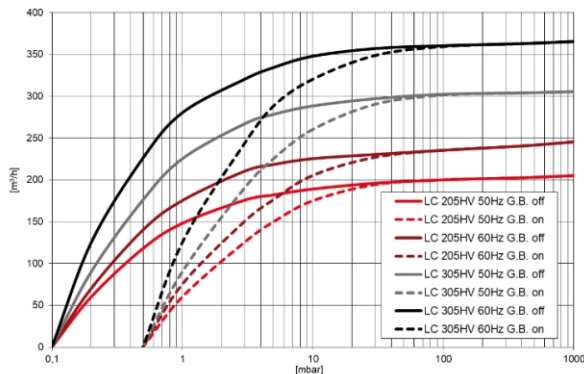

NOTE: Graph shows inlet pressure at a temperature of 68°F (tolerance ±10%)

### MAIN APPLICATION FIELDS:

Food packaging

	LC 205HV
Part Number	9603038/SL
Voltage	208-230/460
Nominal Capacity	144.3 CFM
Total Final Pressure (Abs.)	29.92 inHg / .1 Torr
Motor Power	8.9 HP
Nominal r.p.m.	1700
Noise Level dB(A)	71
Weight	375 Lbs
Oil Type	SW 100
Oil Quantity	4 to 5 Liters
Pump Intake/Outlet	2" / 2"
Operating Temperature	158°F - 167°F
Dimensions	37.4" X 21.25" X 17.4"

Please contact the Manufacturer if environmental conditions are different from those prescribed.